

201735 - DK Getriebe MM 1340 DM15 fix mit 1 i.S. FFH 1.091-1.340 GM500 Silber

Technische Zeichnung

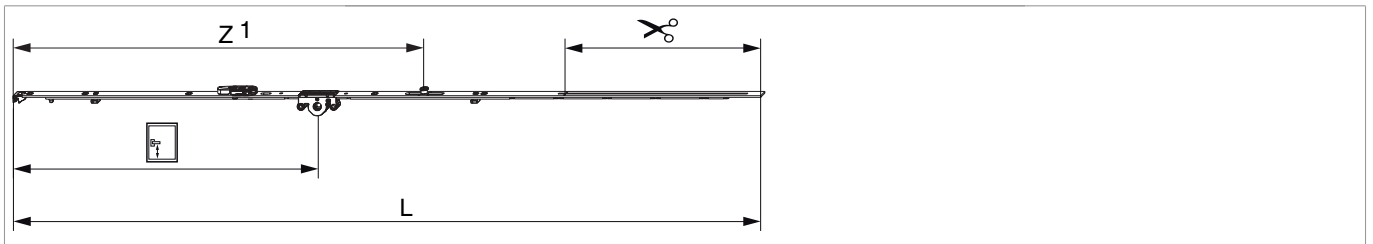

							L		№
Silber	1340	15	500	1.091 - 1.340	260,5	1	1.236,5	10	201735

Schraubpositionstabelle

№		1	2	3	4	5	6	7	8	9	10	11	12	13	14
201735	6	18,5	91,5	328,5	574	685	868,5								

Zapfensitztablelle

№		Z1	Z2	Z3	Z4	
201735	1	640				

Lehren

			№
Einlegelehre MM für Getriebe fix mit Halter 48 mm	661 - 1.340	1	204774 ¹⁾

¹⁾Lehren für Getriebe und Höhentheil verwendbar.

Abmessungen Getriebekasten

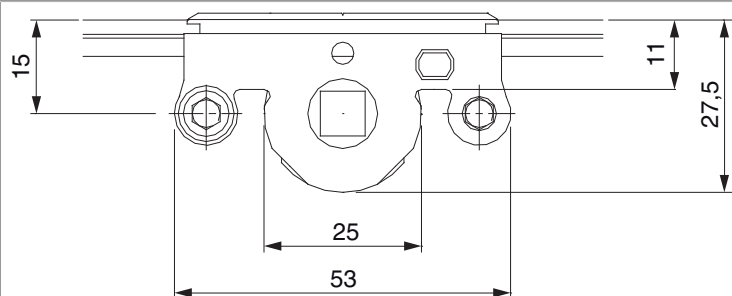

Für Griffbefestigung SPAX-Schraube mit \varnothing 5 mm oder M5 Schraube verwenden.

Bohrbild

Für Holzfenster

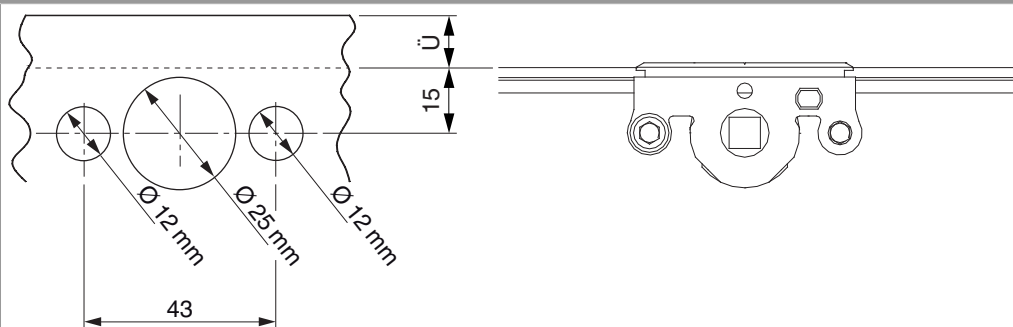

Für Kunststoff- und Aluminiumfenster

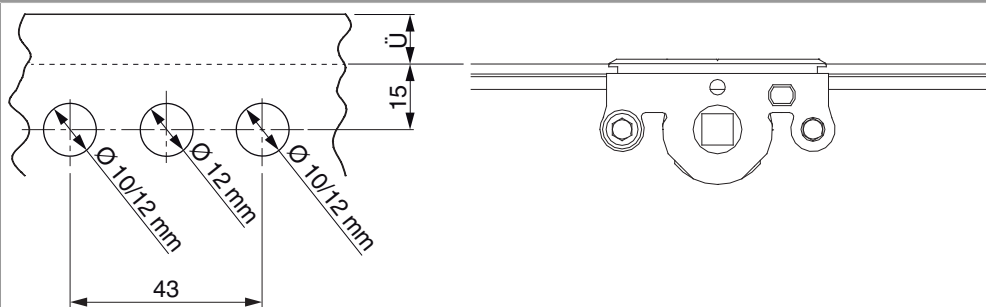



Stanzbild

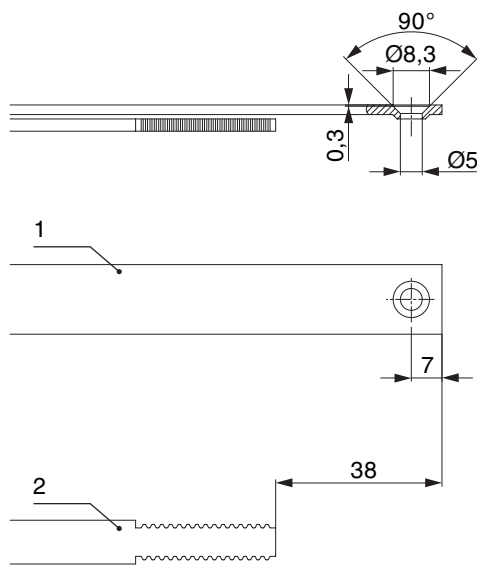

- 1. Stulp
- 2. Riegel

Positionierung Hebeteile

Hebeteile 4L / ohne Türschnapper

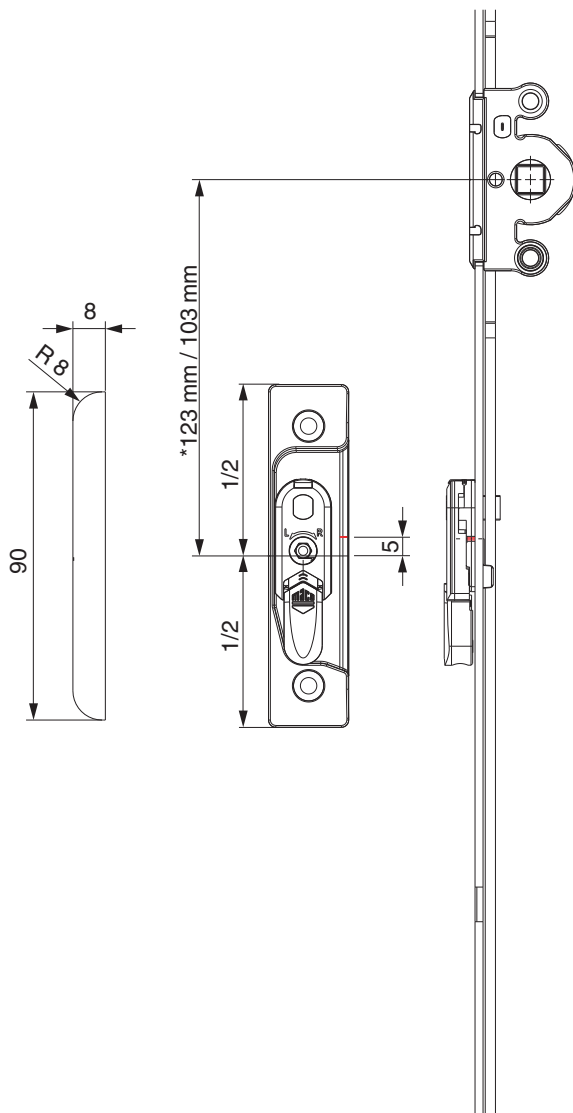

* bei Getriebegröße 660

Hebeteile 4L / mit Türschnapper

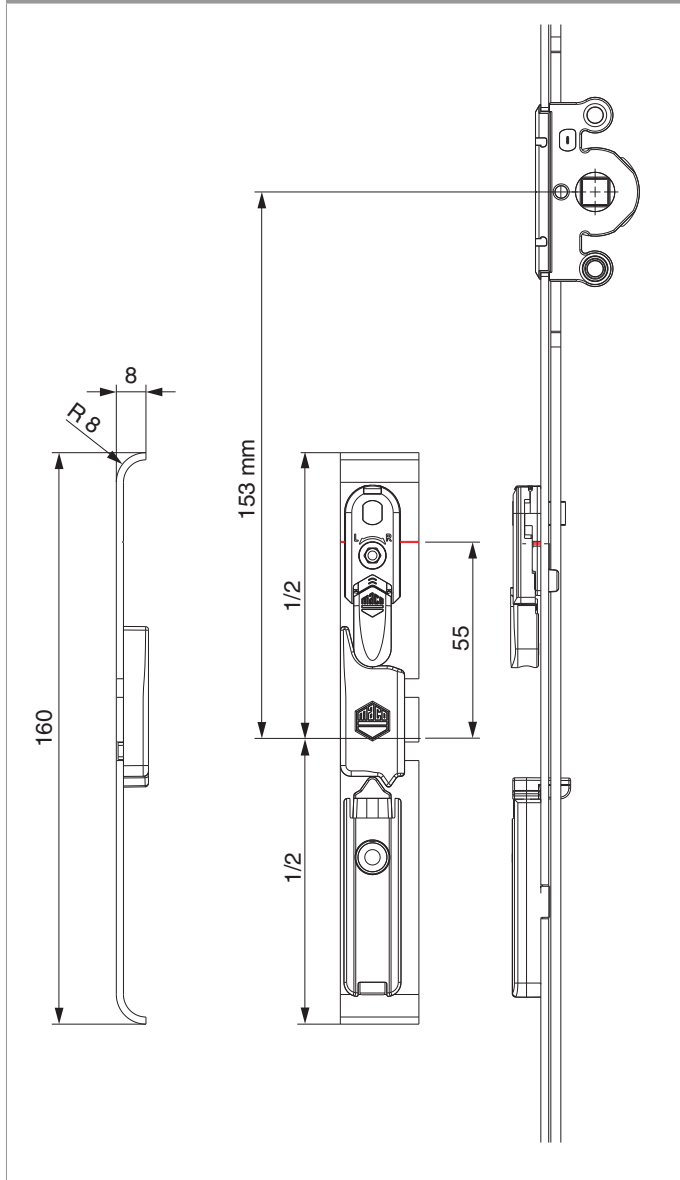



12 mm Falzluft

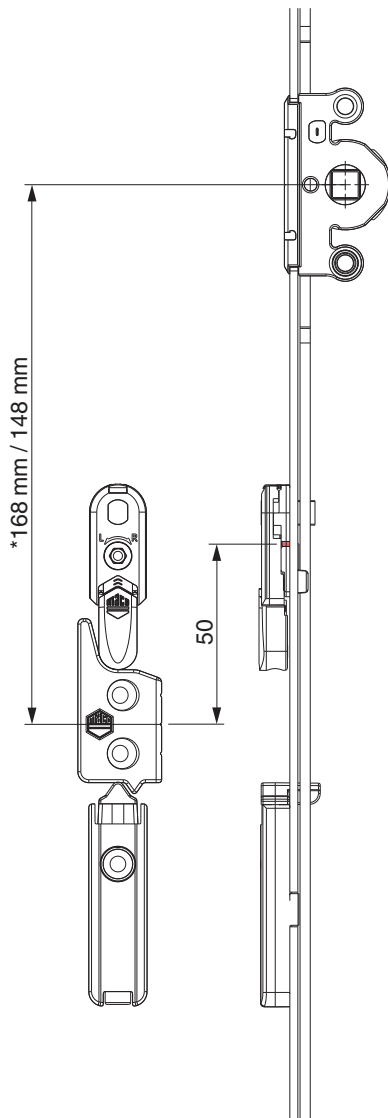

* bei Getriebegröße 660

Ausschwenken und Einstellen der Hebesicherung

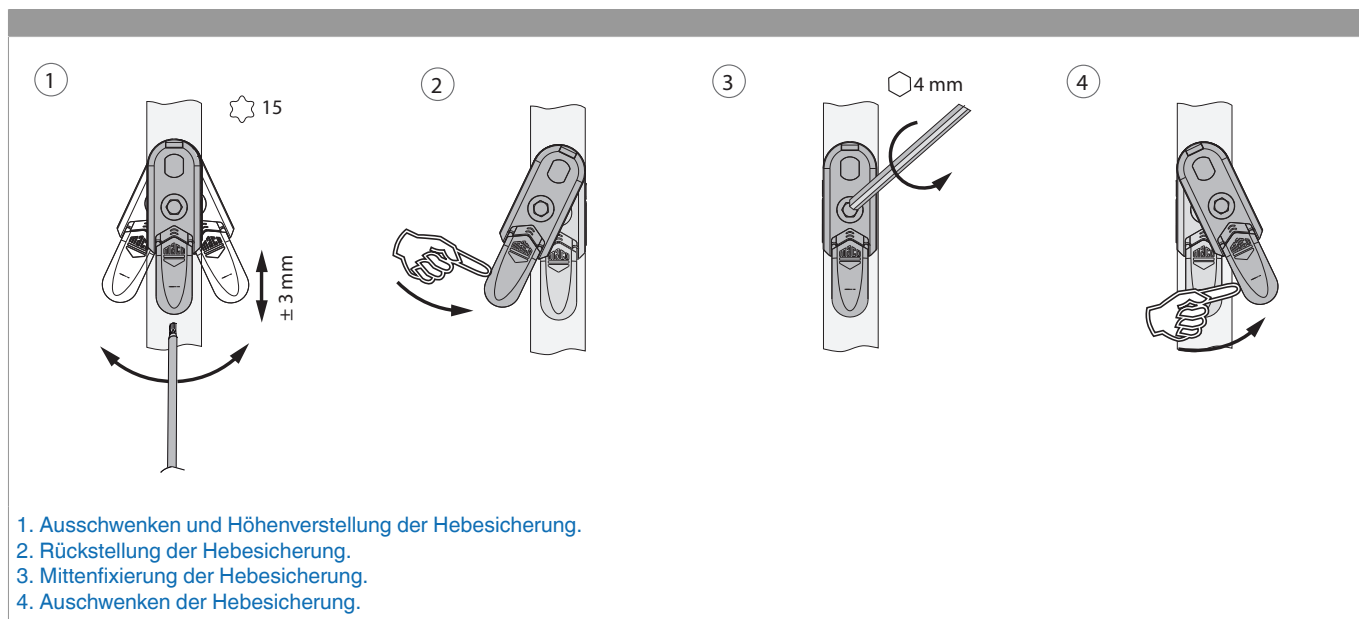

Klipsverbindung

Klipsverbindung einhängen

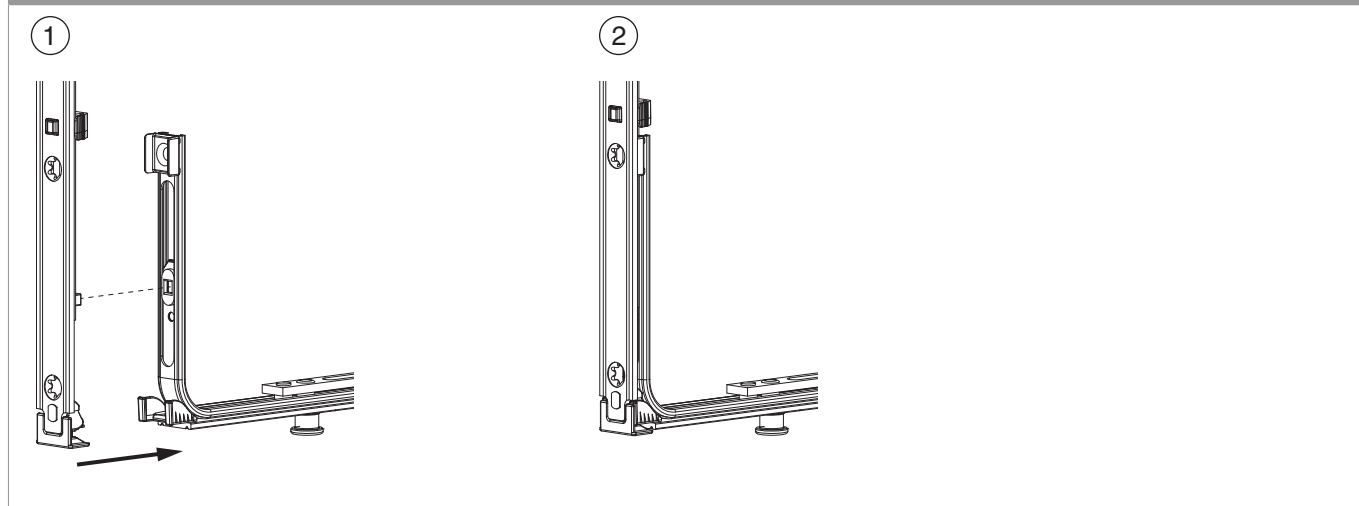

Klipsverbindung aushängen

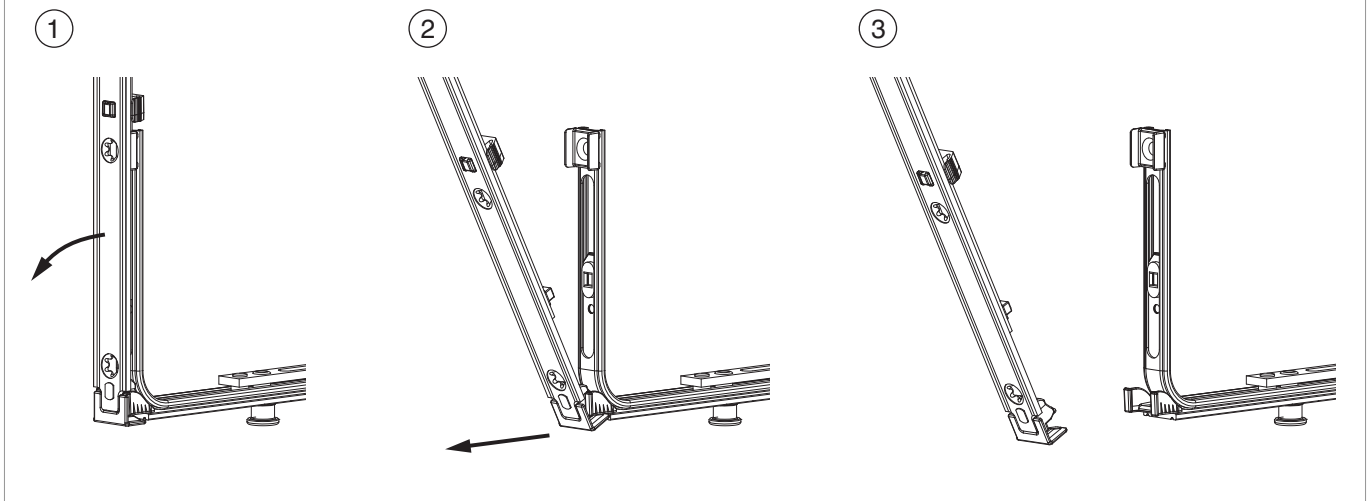

Zahnkastenverbindung

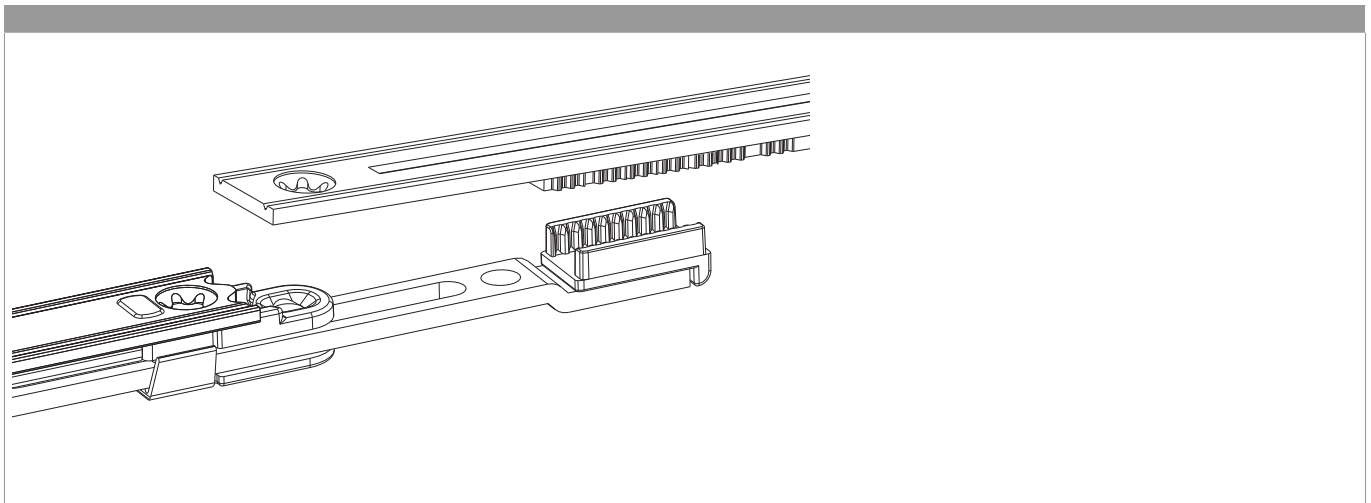

Anpressdruckregulierung

i.S Zapfen und Verschlusszapfen

